



**ACCURATE**  
INDUSTRIES

**ACCURATE INDUSTRIES IS YOUR PARTNER, FOR THE  
IMPROVED PERFORMANCE, PURITY & EFFICIENCY  
OF MATERIAL FLOW SYSTEMS  
FOR MINING & QUARRYING**



## COMPANY PROFILE



ABN 99 657 158 524  
6/23 Ashtan Place, Banyo, QLD, 4014, Australia  
WEBSITE: [www.accurateindustries.com.au](http://www.accurateindustries.com.au)  
PHONE: 1300 101 666  
EMAIL: [admin@accurateindustries.com.au](mailto:admin@accurateindustries.com.au)

# ABOUT US

Established in February 2022 by Matthew Keane (Managing Director), Peter Leeming (Director) & Brad Leeming (Director) to provide high quality service and support for material flow systems performance for the mining industry. Accurate Industries has quickly grown to become a valued service provider to some of the mining industries largest and most recognised names & now offers high quality expertise, service and products from multiple locations to cover the entire country.

We pride ourselves on our commitment to field service, calibration, testing and system performance improvement for our customers & have a deep level of service and product expertise with all major OEM equipment for belt weighers, tramp metal detectors, magnetic separators & weigh feeders. We work together with customers to ensure plant and equipment is reliable, accurate and well maintained, providing site stakeholders with the data required for expert plant balance, product purity and yield results.

## OUR TEAM

Accurate Industries has a collective 100+ years of experience with specification, supply, installation/commissioning & ongoing maintenance of weighing & measuring instruments. We are proud to be owned & lead by people with real life “On The Tools” experience.



### **Matthew Keane:**

Managing Director.  
18+ Years Weighing & Measurement Industry Experience. Certificate III Electronics /Instrumentation, Licenced NMI verifier, Diploma Management.

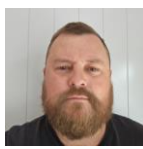

### **Brad Leeming:**

Service Director.  
16+ Years Weighing & Measurement Industry Experience. Certificate III Electrical Fitter Mechanic, Licenced NMI verifier.

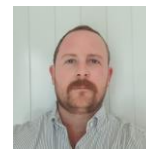

### **Peter Leeming:**

Projects Director.  
11+ Years Weighing & Measurement Industry Experience. Certificate III Electrical Fitter Mechanic, Licenced NMI verifier.



### **Peter Gensch:**

Senior Technical Specialist  
30+ Years Weighing & Measurement Industry Experience.  
Certificate III Electrical / Instrumentation Technician, Diploma Electrical Engineering Industrial Control, Cert III in Programmable Logic Controllers, Cert III Electrical Trade, Cert IV in Computer Technology, Cert IV in Electronics and Communications.



### **Tim Francis:**

Business Development.  
30+ Years Weighing & Measurement Industry Experience. Certificate III Electronics Technician, Certificate III Instrument Fitter, Associate Diploma Electrical Engineering, GAICD.



## OUR VISION

Excellence in efficiency, accuracy, purity & performance of material flow systems for all industries.

## OUR MISSION

To be trusted advisors & partners to industry by providing the best products, service & expertise.

### WHAT WE BELIEVE IN

- Developing Relationships with our customers to deliver Best In Class outcomes
- Providing Accurate, Reliable & Honest service & information for Customers
- Specifying & supplying the Correct Equipment for the application every time

**S**AFETY

**T**RUST

**A**CCURACY

**R**ESPECT

**T**EAM

## OUR CORE VALUES

We work safely & leave safely every day whilst taking responsibility for the safety of others.

We act with credibility, professionalism, and integrity in all that we do.

It is in our name & it is in our DNA. We believe in Accurate communications, Accurate equipment, Accurate advice, & Accurate outcomes for all.

We recognise each other's differences and show consideration for one another and the environment we live in.

We combine individual strengths to develop exceptional results.

# OUR PRODUCTS

Accurate Industries offers a full range of equipment for the protection of plant assets (Magnetic Separators & Tramp Metal Detectors), & the measurement & optimisation of materials flow systems (Belt Weighers & Weigh Feeders) to improve performance, balance, purity & yield.

## MEASURE

## CONTROL

## OPTIMISE

### BELT WEIGHERS

Gain control & system balance

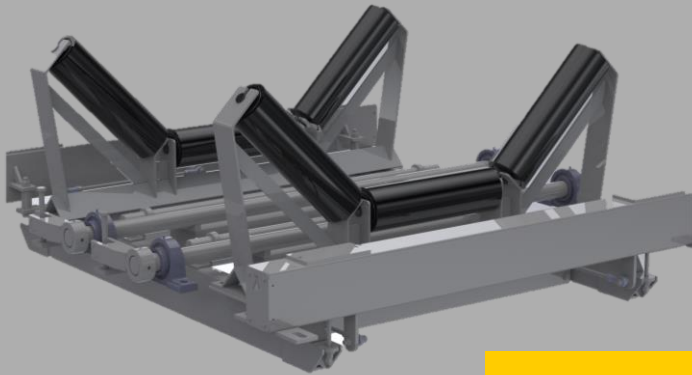

#### PRECISE

The highest possible accuracy for the conditions

#### ROBUST

Made for the environment, our Belt Weighers are built to last

#### FLEXIBLE

Flexible designs to meet all needs & conveyor types

### WEIGH FEEDERS

Dictate flow rates. Precisely dose & blend

#### PRECISE

Feed specific amounts or rates at high accuracy

#### EFFICIENT

Minimise product 'Give Away' with precise control

#### FLEXIBLE

Flexible designs to meet a variety of applications





## DETECT

## PROTECT

## PURIFY

### PROTECT

Safeguard important upstream assets

### QUALITY

Improve product purity

### EFFICIENT

Never stop the material flow

## MAGNETIC SEPARATORS

The Front Line for tramp metal detection & removal.



## TRAMP METAL DETECTORS

The true “Last Line” of defence for critical assets that simply demand protection



### PROTECT

Safeguard important upstream assets

### DE-RISK

Avoid unnecessary downtime

### CONFIDENCE

The ultimate ‘back up’ system



# OUR SERVICE & SPARES

- All site staff have current Coal Board Medical Certificates
- All site vehicles are mine/quarry site compliant
- All site staff are equipped with mine & quarry compliant PPE & clothing
- All site staff hold trade certificate level qualifications
- All site staff are fully registered & National Measurement Institute of Australia (NMI) licenced



## 4 Sales & Service Locations National Coverage



# OUR CAPABILITIES

To deliver on our commitment to provide improved performance & efficiency, Accurate Industries offers a full suite of turnkey capabilities:



**CONSULTATION & DESIGN**



**CALIBRATION & TESTING**



**SYSTEM & SPARE PARTS SUPPLY**



**REMOTE SUPPORT**



**INSTALLATION & COMMISSIONING**



**QUALITY REPORTING**



**REPAIRS, SERVICE & MAINTENANCE**



**RECOMMENDATIONS**

## OUR PARTNERS



## OTHER BRANDS WE SERVICE

- Thermo Ramsey
- Control Systems Technology (CST)
- Process Automation/Real Time Instruments (RTI)
- TecWeigh & more.

## OUR CUSTOMERS





**ACCURATE**  
INDUSTRIES

**BELT WEIGHER** ● **TRAMP METAL DETECTOR**  
**MAGNETIC SEPARATOR** ● **WEIGH FEEDER**

**SALES**

**SERVICE**

**SPARES**



**ABN 99 657 158 524**  
**6/23 Ashtan Place, Banyo, QLD, 4014, Australia**  
**WEBSITE: [wwwaccurateindustries.com.au](http://wwwaccurateindustries.com.au)**  
**PHONE: 1300 101 666**  
**EMAIL: [admin@accurateindustries.com.au](mailto:admin@accurateindustries.com.au)**

